

BEN 14 IM, miniexcavator, with its transportation weight of 1350 Kg only, is suitable to be loaded and moved on vehicles with total ground weight (full loaded) of 3.5 tons. and also on small trailers.

- Original design, with reduced slew radius (only 650 mm) which totally protects the engine bonnet makes this machine be classified as a SR (Short Radius) miniexcavator
- Cushioned and adjustable seat which ensures the control of the machine in full security and comfort. Also tilting to allow easy maintenance of the main components.
- Lock of all the pilot assisted controls and levers when the armrest is lifted, thus excluding the danger of any undesired and uncontrolled movement caused by the accidental push of the control levers and pedals, when getting on and off the machine.
- Extraordinary maneuverability due to the use of pilot assisted controls (joy-sticks) to operate arms and bucket.
- Particular care has also been given to design, maintenance operations and operators' safety.
- Its round shaped design recalls the other models of the range, thus creating a continuity of style and image.

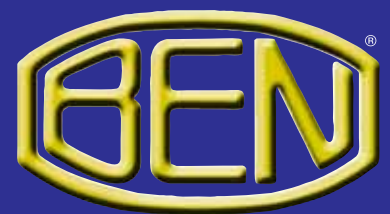
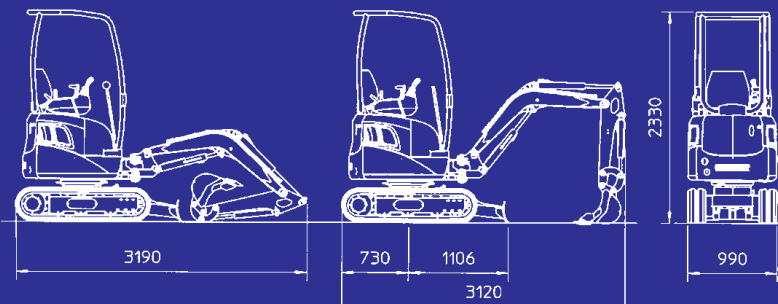
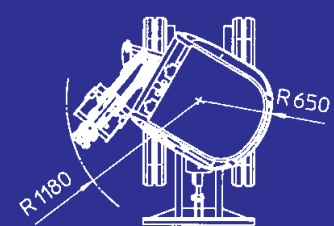
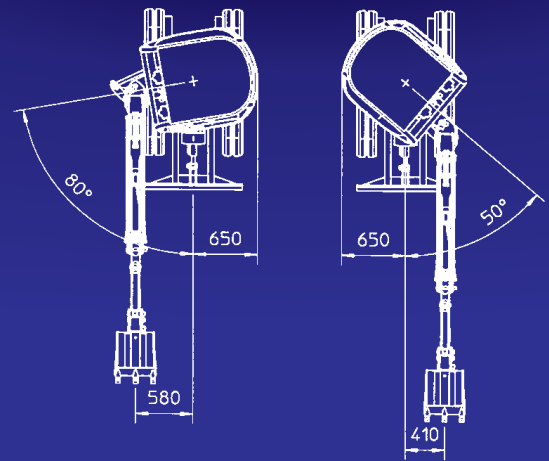
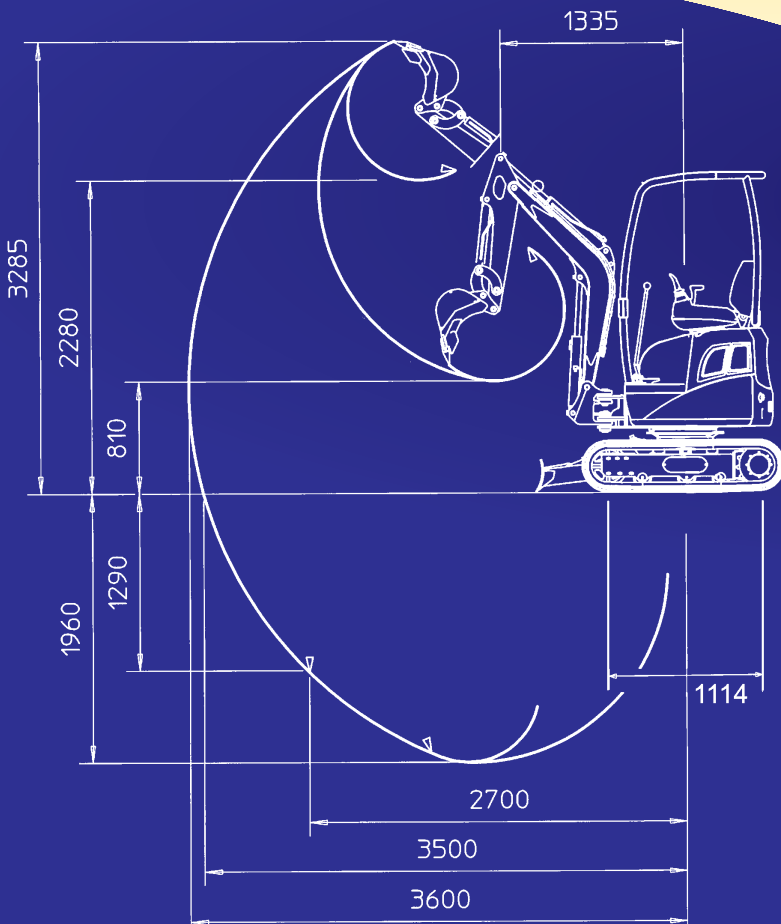

**STANDARD EQUIPMENT**

- Canopy according to TOPS, FOPS norms
- Standards bucket of 300 mm (SAE capacity lt. 25)
- Hydraulic Power Take-Off (P.T.O.)
- Operator's and Spare parts manuals

OPTIONAL EQUIPMENT

- Buckets of mm 250, 350, 450, 500, standard, for rocks and for Quick Hitches
- Bucket for slopes, standard or swivelling
- Buckets for cleaning
- Mechanical or hydraulic quick hitch
- Hydraulic breaker
- Hand breaker
- Hydraulic drill/rig

ENGINE

- Make and model Kubota D902
- Max power at 3200 rpm (DIN 6271) HP/Kw 20.4/15
- Rated horse power at 2400 rpm HP/Kw 19/14
- Cylinders N° 3
- Displacement cm³ 898
- Cooling water
- Battery N° 1 - 12 V - 44 Ah

PERFORMANCES

- Shipping weight Kg 1350
- Operating weight Kg 1420
- Break out force daN 1200
- Digging force daN 800
- Travel speed Km/h 1.8
- Max gradient capacity more than % 100
- Specific ground pressure Kg/cm² 0.285

REFUELLING

- Fuel tank capacity lt 20
- Hydraulic oil tank capacity lt 19

HYDRAULIC SYSTEM

- Hydrostatic transmission with orbital motors and planetary reduction gears with negative brakes
- Traveling counter-balance valves
- N. 2 gear pumps Lt/min 15 x 2
- Total delivery Lt/min 30
- Auxiliary hydraulic flow for P.T.O Lt/min 30
- Max working pressure bar 180
- Slew speed (with orbit motor) g/min 9.5
- Boom, arm, bucket and slew actuated by servo-controlled joysticks
- Mechanical levers to control track; pedals to control boom swing and single and double effect P.T.O.
- Lever to control dozer blade
- Heat exchanger for oil cooling

UNDERCARRIAGE

- Box section steel frame
- Track type and width mm rubber 200
- Track bearing rollers N° 3+3 low/guide block
- Track tensioning adjusting screw
- Dozer blade mm 250 x 990



Via San Pier Grisologo, 26 - 40026 IMOLA (Bo)
 info@benatigroup.com - parts@benatigroup.com