

BEN 60 IM

- Innovative design with the tail always remaining within the width of the tracks (Zero Tail Swing)
- Suspension and adjustable operator's seat increases productivity by providing optimum comfort.
- Travel levers and servo-controls disabling system by armrest lifting prevents accidents due to unexpected machine movement during entry or exit from the driving place.
- Extraordinary manoeuvrability due to the use of pilot assisted controls (joy-sticks) to operate arms and buckets.
- Straight travel contemporary with all arms/bucket manoeuvring.
- Rollers and idler wheels with rolling bearings replacing the guide bushings for a remarkable increasing in the traction and life time performances.
- The round shape design recalls the other models of the range, thus creating a continuity of style and image.

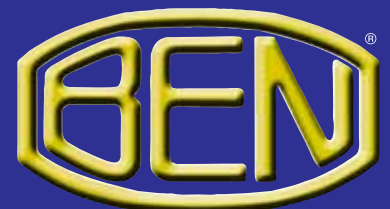

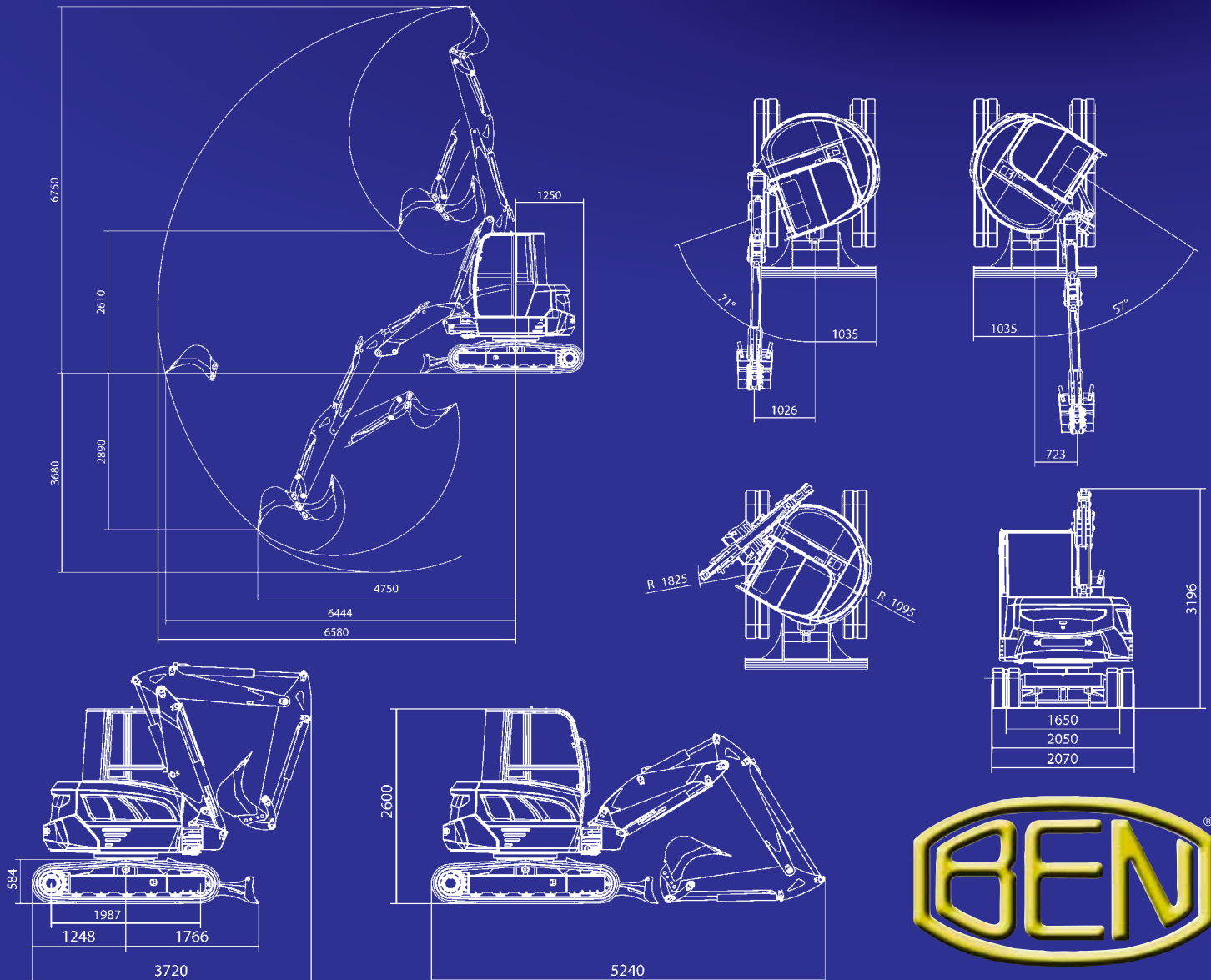

miniexcavator

BEN 60 IM

STANDARD EQUIPMENT

- Cab with heating system according to TOPS norms
- Standard bucket of mm 600 (SAE capacity lt. 157)
- 2-speeds travel electric switch
- Articulated boom
- Regenerative system on dipstick arm
- 1550 mm. Long dipstick
- Hydraulic Power Take-Off (P.T.O.)
- Automatic transmission system
- Operator's and spare parts manuals

OPTIONAL EQUIPMENT

- Buckets of mm from 300 to 1000 standard, for rocks and for Quick Hitches
- Buckets for slopes standard or swivelling
- Buckets for cleaning
- Mechanical or hydraulic Quick Hitches
- Hydraulic breaker
- Hand breaker
- Hydraulic drill
- Grass-brush cutter
- Steel tracks
- 1850 mm longer arm
- Air conditioning

ENGINE

- Make and model Kubota V2403M-T
- Intake system turbocharged
- Max power at 2700 rpm (DIN 6271) HP/Kw 59 / 44
- Rated horse power at 2200 rpm HP/Kw 52 / 38
- Cylinders N°4
- Displacement cm³ 2434
- Cooling water
- Battery N° 1 - 12 V - 105 Ah

PRESTAZIONI

- Shipping weight Kg 5600
- Operating weight Kg 5750
- Break out force daN 3970
- Digging force daN 2900
- Travel speed Km/h 2.7 / 4.7
- Max gradient capability more than %100
- Specific ground pressure Kg/cm² 0.330

HYDRAULIC SYSTEM

- Hydrostatic transmission with piston motors and planetary reduction gears with negative brakes and automatic shift.
- Travelling counter-balance valves.
- N.2 variable displacement piston pumps + gear pump Lt/min 60 x 2 + 45
- Total delivery Lt/min 165
- Auxiliary hydraulic flow for P.T.O Lt/min 105
- Max working pressure bar 250/220
- Slew speed g/min 9.0 (with piston motors and negative brake)
- Hydraulic servo-controlled joystick to operate bucket, arms, slew.
- Hydraulic servo-controlled pedals for driving, off-setting and simple/double effect Power Take Off; lever control for the refilling blade.
- Heat exchanger for oil cooling.

UNDERCARRIAGE

- Box section steel frame
- Track type and width. mm rubber 400
- Track bearing rollers N° 5+5 low/1+1 up
- Track tensioning grease
- Dozer blade mm 370 x 2070

REFUELLING

- Fuel tank capacity lt 80
- Hydraulic oil tank capacity lt 50



BENATI

s.r.l.
group

Via San Pier Grisologo,26 - 40026 IMOLA (Bo)
info@benatigroup.com - parts@benatigroup.com

www.benati.it